

Advanced Technology Tension Clutches

P-220
819-0339

Installation Instructions



Contents

Installation	2
Clutch Repair – On the Shaft	4
Clutch Service – Major	7
Troubleshooting.	15
Dimensions	16
Specifications	16
Exploded View and Parts List.	18
Warranty	Back Page

⚠ WARNING Failure to follow these instructions may result in product damage, equipment damage, and serious or fatal injury to personnel.

The Warner Electric Advanced Technology Tension (ATT) clutch you have purchased has been designed to provide long and trouble-free service. It is a rugged and durable unit that is rebuildable with both friction face replacement and complete clutch rebuild kits discussed in this service manual. The friction face replacement kit renews the friction surfaces, while the complete clutch rebuild kit includes new bearings, components and hardware in addition to the friction faces.

This service manual includes instructions required for installation, repair on the shaft, and major rebuilding, as well as troubleshooting information, specifications, dimensions, an exploded view and parts list. Please refer to the Table of Contents above for the section page numbers.

All installation and repair involving clutches must be carried out in accordance with the procedures specified in the service manual. All stated or implied manufacturer warranties are voided if this product is not installed and serviced in accordance with these instructions.

Clutch Installation

1. Remove your ATT Clutch from its shipping carton and inspect it thoroughly to ensure that it has arrived in good condition.

An accessory kit included with your clutch contains a key, retaining ring, and coil wire retainer. In addition, you may have ordered the optional sheave or timing belt pulley and field restraining strap.

2. Install the factory-ordered sheave or pulley by first inserting the key in its keyway. Place the sheave or pulley so it will fit onto the hub, aligning the keyway with the key and keeping the sheave tapped holes facing away from the clutch. (See Figure 1)



Figure 1

Gently tap the sheave or pulley until it seats against the hub shoulder.

Note: Do not force the pulley or sheave onto the hub if it will not go. Check alignment to assure it is going on evenly. Customer furnished sheaves, pulleys and sprockets must be machined per instructions found on page 16 of this manual prior to installation. After machining, install per the above instructions. (See Figure 2)



Figure 2

3. Install the furnished sheave or pulley retaining ring with retaining ring pliers. (See Figure 3)



Figure 3

CAUTION When installing this or other retaining rings, be sure to hold the ring with one hand so it will not spring away, endangering personnel and property, should the pliers lose their grip on the ring. Safety glasses should always be worn when installing or removing retaining rings.

4. If used, install the Warner Electric conduit box in accordance with its furnished instructions.
5. Place the ATT clutch onto its shaft, making sure it is properly positioned over the shaft key. (See Figure 4)

Note: The Warner Electric special furnished key must be used with ATTC-25-7/8" bore units.



Figure 4

6. Tighten the hub setscrews into the shaft (See Figure 5) to the appropriate torque for your size unit:

Size	Torque
25	80 in.lbs.
55	160 in.lbs.
115	275 in.lbs.

Assure proper alignment of driving and driven sheave, pulley or sprocket before tightening the setscrews.

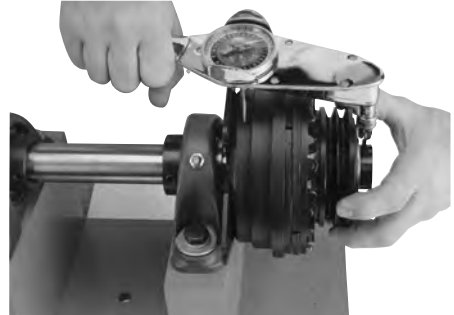

Figure 5

7. Install the field restraining arm. (See Figure 6)



Figure 6

Note: The field must retain a degree of movement freedom to compensate for bearing and shaft alignment tolerances.



Figure 7

8. When using a Warner Electric tension control, follow the connection diagram supplied with the control. (See Figure 7)

Note: If a Warner Electric TCS-210, -220, -310, or -320 control is used, add a 68 ohm, 25 watt resistor or a dummy coil (part no. 275-3843) across the current sense circuit. Although the TCS series controls are recommended, a MCS control can be used with normal hook-up.

9. Your ATT clutch is now ready for its static test. Apply DC voltage to the clutch coil through the clutch control. The armature should pull against the friction material face.
10. Install the drive belt or chain.
11. Run the clutch under its operating load.
12. Your ATT clutch may not achieve its full torque until after a short “break-in” period. To break in the clutch, cycle it on and off under full load at operating speed a minimum of ten times in quick succession.

Your ATT clutch is now ready to run.

Complete Clutch Repair - On the Shaft

The new ATT design incorporates the latest in advanced technology providing a rugged, durable, patented design for long life, and maximum heat dissipation. Patented, easy to replace, friction surfaces extend the design life for continued like-new performance. The ATT offers complete repair on the shaft following ten easy steps. The repair can be completed utilizing the parts in the friction face replacement kit.

1. Move the clutch rotor towards the field for disassembly and reassembly. (See Figure 8)

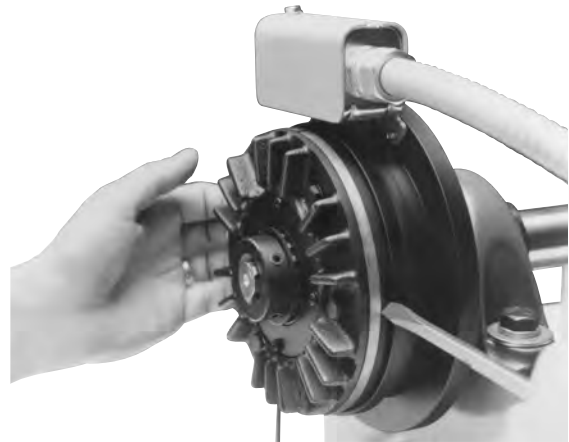

Figure 8

2. Remove hex head capscrews, washers and lock-washers to loosen the armature segments from the cast iron carrier. (See Figure 9)

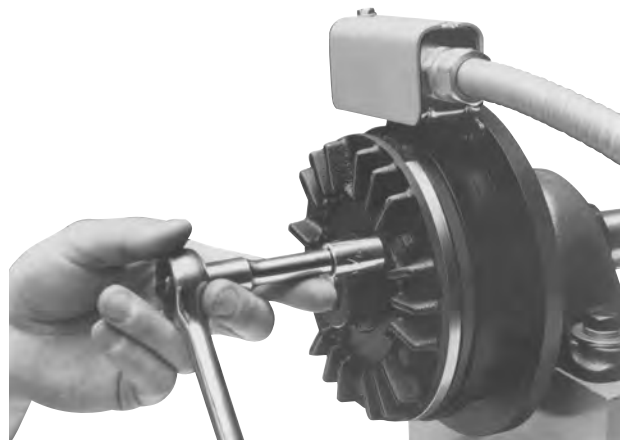

Figure 9

3. Lift out the two worn armature segments.
(See Figure 10)

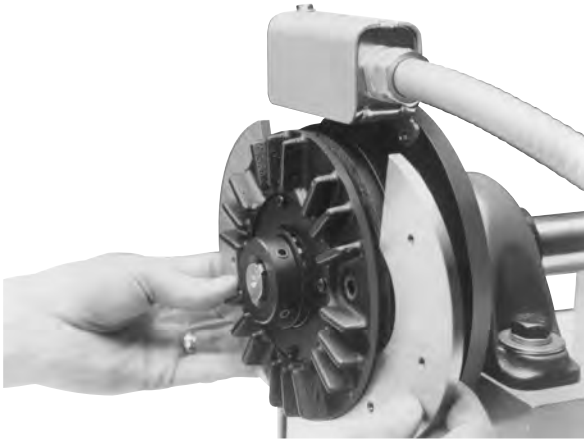

Figure 10

Note: Although an AT brake is shown in these instructions, identical procedures apply to a clutch.

4. Remove the screws that attach the friction material segments to the clutch rotor through the appropriate access holes. (See Figure 11)

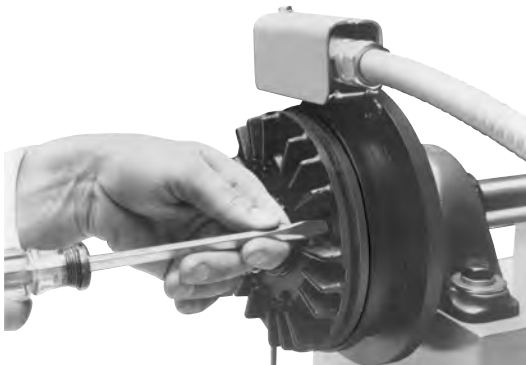

Figure 11

5. Lift out the worn friction material segments. (See Figure 12)

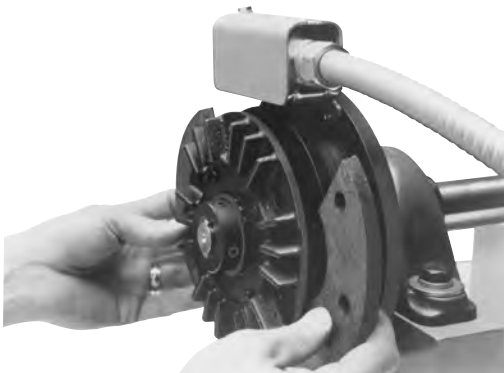

Figure 12

6. Insert two new friction material segments. The recessed holes should be facing away from the magnet body. (See Figure 13)

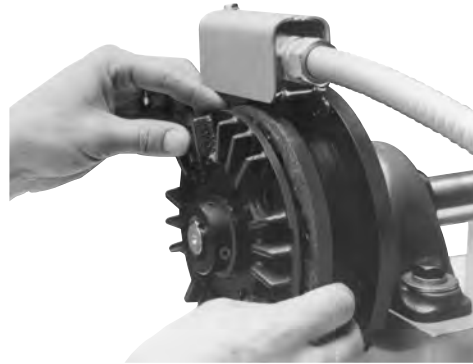

Figure 13

7. Attach the new friction material segments to the clutch rotor or brake magnet with screws through the appropriate access holes. Apply one drop of Loctite® (grade AA or equivalent) to each screw. (See Figure 14)

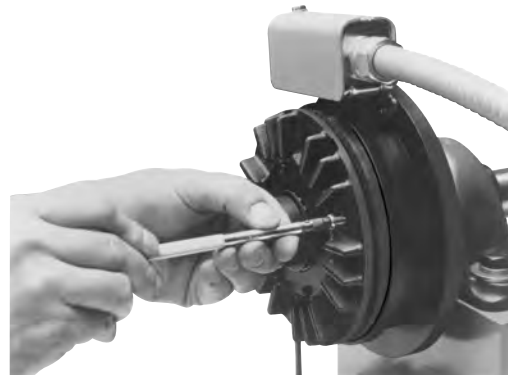

Figure 14

Note: Use only the screws included with the repair kit since any other screws may damage the unit. Tighten screws to 18 to 22 inch pounds torque.

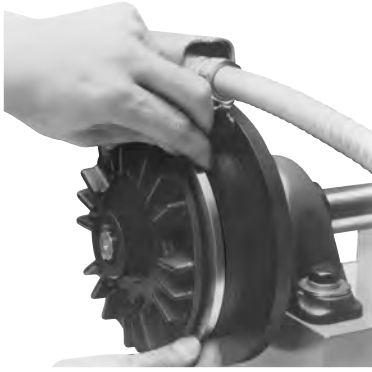

Figure 15

8. Insert the two new armature segments. (See Figure 15)
9. Attach the new armature segments to the cast iron carrier with hex head capscrews, lockwashers and washers. Apply one drop of Loctite (grade AA or equivalent) to each screw. (See Figure 16) Tighten to the appropriate torque for your size unit.

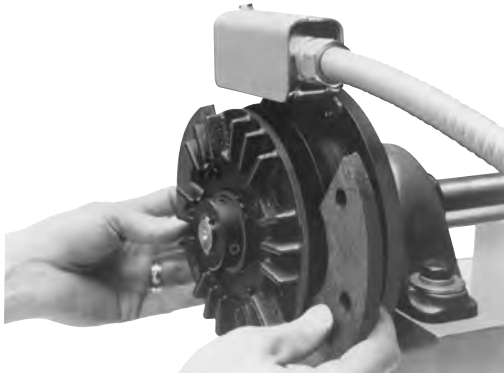

Figure 16

Size	Torque
ATT 25	29-35 in.-lbs.
ATT 55	60-84 in.-lbs.
ATT 115	60-84 in.-lbs.

10. Reset the gap by moving the clutch rotor away from the field or brake armature toward the magnet. (See Figure 17)



Figure 17

11. Your ATT clutch is now ready for its static test. Apply DC voltage to the clutch coil through the clutch control. The armature should pull against the friction material face.
12. Install the drive belt or chain.
13. Run the clutch under its operating load.
14. Your ATT clutch may not achieve its full torque until after a short "break-in" period. To break in the clutch, cycle it on and off under full load at operating speed a minimum of ten times in quick succession.

Your ATT clutch is now ready to run.

Clutch Service – Major

A major rebuild of an ATT clutch can be accomplished by following these instructions to replace the parts furnished in the appropriate Warner Electric clutch rebuild kit. Part numbers and component descriptions for these kits are found on page 19 of this manual. Item numbers in these instructions refer to clutch components shown on page 18, exploded view. Proceed as follows:

1. Turn off all power to the clutch.
2. Disconnect the coil wires from the incoming control unit wires. (See Figure 18)



Figure 18

3. Disconnect the field anti-rotation pin or field restraining arm (Item 19). (See Figure 19)

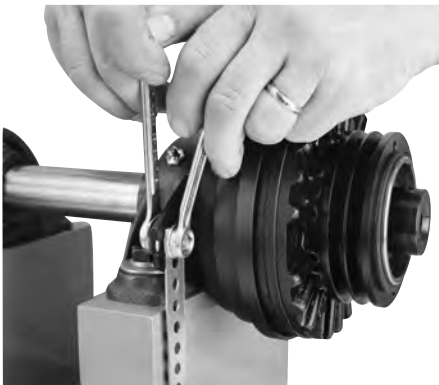

Figure 19

4. Loosen the setscrews (Item 8) which hold the clutch to its shaft. (See Figure 20)



Figure 20

5. Remove the clutch from its shaft by pulling and/or gently tapping the hub with a hammer and drift. (See Figure 21)



Figure 21

Note: Do not hit the outer portion of the clutch outboard of the hub as this may severely damage it.

6. Remove the retainer ring (Item 13). (See Figure 22)



Figure 22

CAUTION When removing this or other retaining rings, be sure to hold the retaining ring with on hand so it will not spring away and endanger personnel and property should the pliers lose their grip on the ring. Safety glasses should always be worn when installing or removing rings.

7. Remove the field assembly (Item 12) and bearing (Item 11) by locating and supporting on the rotor outer diameter (Item 10) and pressing on the hub (Item 7). (See Figure 23)



Figure 23

8. Remove the bearing (Item 11) from the field assembly (Item 12) by pressing on the inner race while supporting the field assembly on its face. (See Figure 24)

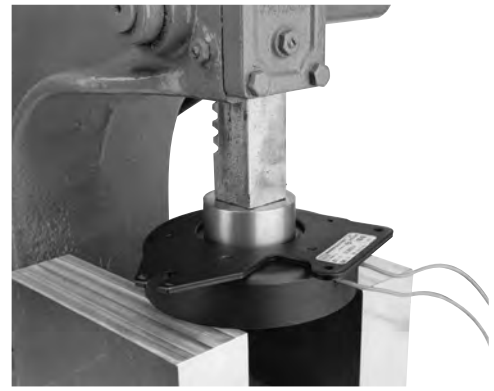

Figure 24

Note: Use caution to avoid damaging the epoxy covering the coil.

9. Press the new bearing (Item 11) into the field assembly by pressing on the bearing outer race. **Do not press on the bearing inner race or damage to the bearing will result, making it unusable.** (See Figure 25)



Figure 25

10. Remove the rotor assembly (Item 10) from the hub (Item 7). (See Figure 26)



Figure 26

11. Remove the screws which retain the friction disc segments. (See Figure 27)



Figure 27

12. Lift the friction disc segments off the rotor. (Item 10) (See Figure 28)



Figure 28

13. Clean all foreign matter from rotor mounting surface. Install the new friction disc segments (Item 10-1) with new screws included with the kit. (See Figure 29)

Note: Use only the screws included with the kit as any others may damage the clutch.



Figure 29

Apply a drop of Loctite grade AA or equivalent to each screw prior to installation. Tighten each screw to 18-22 in. lb. torque. (See Figure 30)



Figure 30

14. Remove the snap ring (Item 1) from the armature hub assembly. (See Figure 31)



Figure 31

CAUTION When installing or removing this or other retaining rings, be sure to hold the ring with one hand so it will not spring away, endangering personnel and property should the pliers lose their grip on the ring. Safety glasses should always be worn when installing or removing retaining rings.

Remove the pulley, sheave, or sprocket if it interferes with removing the capscrews (Item 9-2). (See Figure 32)

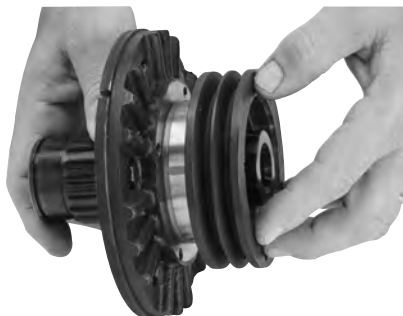

Figure 32

15. Disassemble the armature hub assembly by removing capscrews (Item 9-2), lock washers and armature segment (Item 9-1). (See Figure 33)



Figure 33

Remove the setscrews (Item 8). (See Figure 34)



Figure 34

Remove the external and internal retaining rings (Items 3 and 4) from the splined hub (Item 7) and the armature hub (Item 2). (See Figure 35)



Figure 35

Locate and support on the sheave end of the assembly near the fins and press on the field end of the splined hub (Item 7). (See Figure 36)

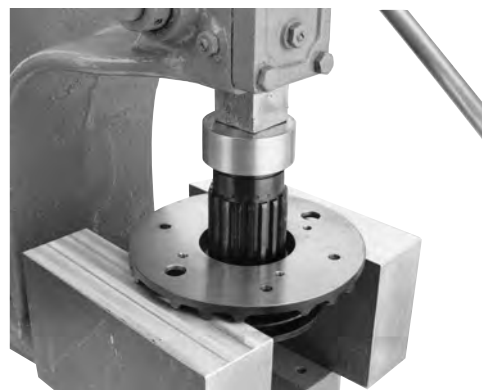

Figure 36

To remove the hub and bearing assembly, remove the bearings (Item 5) and spacer (Item 6) from the hub (Item 7) by pressing them off. (See Figure 37)



Figure 37

Proceed with reassembly per the following instructions:

Note: It is imperative that all bearings be installed exactly as instructed to avoid damage to the bearings.

Apply one drop of Loctite grade AA or equivalent to each capscrew prior to installation. (See Figure 38)



Figure 38

Install the new armature segments (Item 9-1) supplied in the kit onto the armature hub, (Item 2) using capscrews and washers (Items 9-2, and 9-3). (See Figure 39)



Figure 39

Tighten the capscrews (See Figure 40) to the appropriate torque for your size unit:

Size	Torque
25	29-35 in.-lbs.
55-115	60-84 in.-lbs.



Figure 40

16. Install the inner adapter bearing (Item 5) onto the hub, (Item 7) **by pressing on the inner race of the bearing.** With the end of the hub supported as shown in Figure 41, press the bearing until its inner race locates against the hub shoulder.

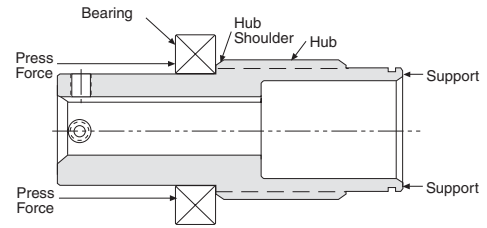

Figure 41

17. Press the hub and bearing into the Adapter Assembly until the outer race of the bearing locates against the shoulder of the adapter hub. Note that the **force is to be exerted on the outer race.** Support the armature face as shown in Figure 42.

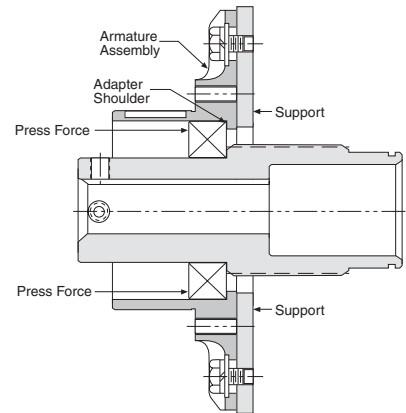

Figure 42

18. Install the spacer (Item 6) as shown in Figure 43.

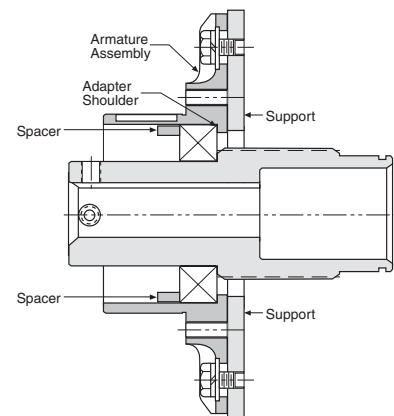

Figure 43

19. Press the outer bearing (Item 5) into place by **applying force evenly against the bearing outer and inner races simultaneously** while supporting the armature face. Continue pressing until the outer race firmly locates against the spacer. (See Figure 44)

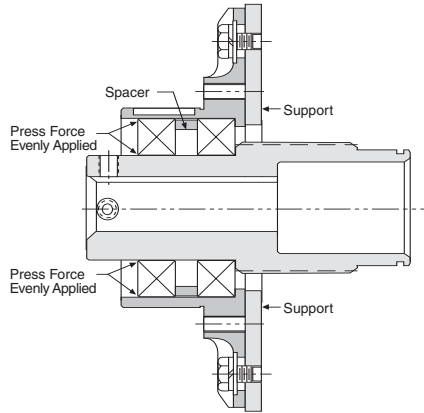

Figure 44

20. Install the external and internal retaining rings (Items 3 and 4) adjacent to the outer bearing. (See Figure 45)



Figure 45

Note: The Armature Assembly must rotate freely on the hub. Inspect to insure that the inner bearing is still firmly located against the adapter shoulder as previously shown in Figure 42. When inspecting, place unit firmly on flat surface with exposed hub end up.

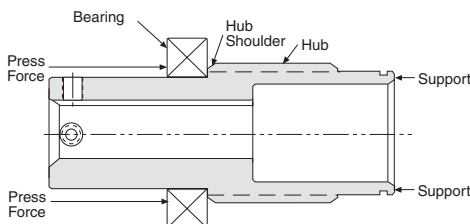

Figure 41

21. Install the rotor assembly onto the hub (Item 7) making sure that the spline teeth are aligned. (See Figure 46)

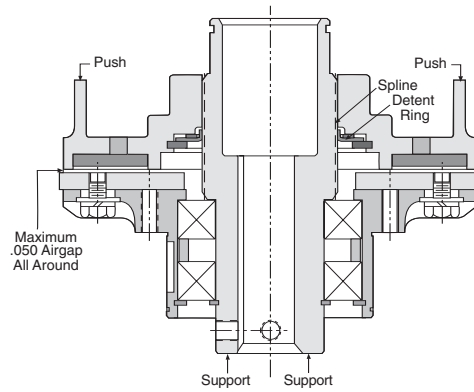

Figure 46

22. Press the field assembly onto the hub by **pushing the inner race of the bearing** while supporting on the hub. Apply force until the inner race of the bearing is located flush against the shoulder adjacent to the spline. (See Figure 47)

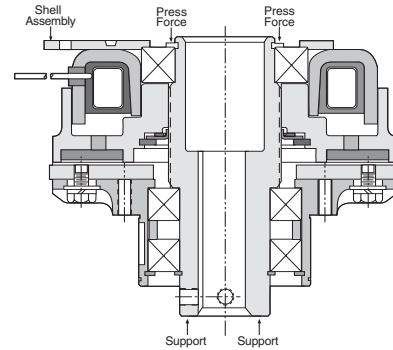

Figure 47

Install the retaining ring (Item 13) on the hub with snap ring pliers. (See Figure 48)
 Rotate the hub. No interference between the shell and rotor is allowable.

CAUTION When installing or removing this or other retaining rings, be sure to hold the ring with one hand so it will not spring away, endangering personnel and property, should the pliers lose their grip on the ring. Safety glasses should always be worn when installing or removing retaining rings.



Figure 48

23. Reinstall the sheave, pulley, or sprocket, and key.
 (See Figure 49)



Figure 49

Reinstall the sheave retainer ring (Item 1) (See Figure 50) and conduit box, if used. Refer to the conduit box installation instructions.



Figure 50

24. Reinstall the clutch assembly on the shaft, placing the key in its keyway. (See Figure 51)



Figure 51

25. Tighten the hub setscrews onto the key (See Figure 52) to the appropriate torque for your size unit:

Size	Torque
25	80 in.-lbs.
55	160 in.-lbs.
115	275 in.-lbs.

Assure proper alignment of driving and driven sheave, pulley, or sprocket before tightening set screws.

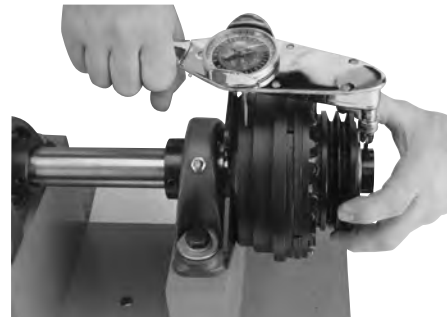

Figure 52

26. Secure the field by its pin or restraining arm accessory to avoid rotation. (See Figure 53)



Figure 53

27. Reconnect the wires. (See Figure 54)



Figure 54

28. Your ATT clutch is now ready for its static test. Apply DC voltage to the clutch coil through the clutch control. The armature should pull against the friction material face.
29. Install the drive belt or chain.
30. Run the clutch under its operating load.
31. Your ATT clutch may not achieve its full torque until after a short “break-in” period. To break-in the clutch, cycle it on and off under full load at operating speed a minimum of ten times in quick succession.

Your ATT clutch is now ready to run.

ATT Clutch Troubleshooting Guide

If performance problems are present after carefully following the instructions in this manual, use the following checklist.

Symptom	Check
Problem Clutch Rotor will not move or engage when power is applied to the coil	Possible Cause <ul style="list-style-type: none"> • Coil Resistance Coil may be open. See Chart 1. • Power Supply Assure proper DC voltage is being delivered to the clutch. • Airgap If greater than .050" around entire periphery, reset gap.
Vibration	<ul style="list-style-type: none"> • Runout Assure that shaft on which the clutch is mounted doesn't have excessive runout. • Shaft Engagement Assure adequate shaft length and diameter engagement in the hub.
Excessive Start or Stop Times	<ul style="list-style-type: none"> • Power Supply Assure proper DC voltage is being delivered to the clutch. • Adequate Burnishing Unit must be run and cycled a few times to achieve full rated torque. • Friction Surfaces Replacement may be required. • Friction Surfaces Installation of replacement friction material or armature segments may be incorrect and not allow full contact.

Clutch/Brake Size	Coil Voltage	Approx. Coil Resistance (Ohms)
25	24	20.6
	90	290
55	24	19.6
	90	230
115	24	16.5
	90	182

Chart 1

Dimensions

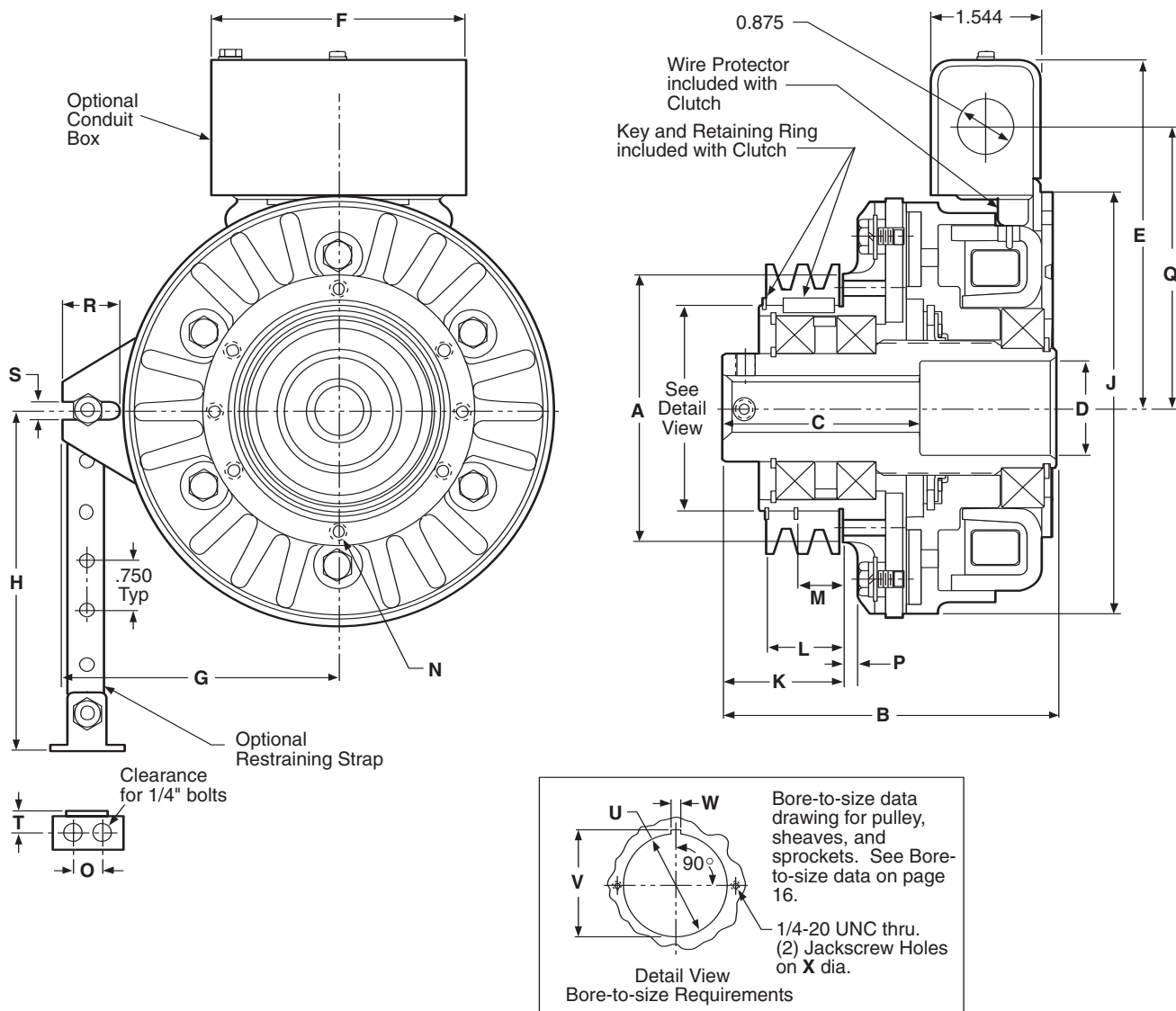

Specifications

Model Size	Voltage DC	Unit	Inertia*-WR ² (lb.ft. ²)	Max. RPM	Weight (lbs.)	Static Torque (lb.ft.)	Dynamic Torque @ 1800 RPM
25	6	Clutch	.048	3600	8	25	12 lb. ft.
	24		.048	3600	8	25	12 lb. ft.
	90		.048	3600	8	25	12 lb. ft.
55	6	Clutch	.173	3600	18	55	20 lb. ft.
	24		.173	3600	18	55	20 lb. ft.
	90		.173	3600	18	55	20 lb. ft.
115	6	Clutch	.483	3600	28	115	30 lb. ft.
	24		.483	3600	28	115	30 lb. ft.
	90		.483	3600	28	115	30 lb. ft.

() denotes millimeters

Model	A Max. Dia.	B Max.	C Nom.	D Nom. Dia.	E Max.	F Max.	G Max.	H Max.	J Max. Dia.	K Max.	L Nom.	M Max.	T Nom.
25	3.60 (91.44)	4.39 (111.51)	2.375 (60.33)	1.080 (27.43)	4.748 (120.60)	3.767 (95.68)	3.282 (83.36)	5.11 (129.79)	4.822 (122.49)	1.68 (42.67)	1.003/.991 (25.48/25.17)	.715/.703 (18.16/17.86)	.375 (9.53)
55	3.95 (100.33)	4.935 (125.35)	2.925 (74.30)	1.40 (35.56)	5.182 (131.62)	3.767 (95.682)	4.032 (102.412)	5.11 (129.792)	6.275 (159.39)	1.817 (46.152)	1.113/1.101 (28.27/27.97)	-	.375 (9.53)
115	5.254 (133.452)	5.977 (151.822)	3.102 (78.792)	1.86 (47.242)	6.089 (154.662)	3.767 (95.682)	4.246 (107.852)	10.11 (256.792)	7.906 (200.812)	2.467 (62.662)	1.539/1.523 (39.09/38.68)	-	.375 (9.53)

Model	No. of Holes	N Thread Size	Max. Depth	Bolt Circle	O Nom.	P Nom.	Q Nom.	R Min.	S Min.
25	3	1/4-20	.500	3.00	.500 (12.7)	.036 (0.91)	3.586 (91.10)	.752 (19.08)	.279 (7.09)
55	4	1/4-20	.635	3.50	.500 (12.7)	.081 (2.06)	4.156 (105.56)	.722 (18.34)	.265 (6.73)
115	4	5/16-18	.830	4.75	.500 (12.7)	.237 (6.02)	4.927 (125.15)	.504 (12.80)	.265 (6.73)

Bore to Size Data

Model	U Bore Dia.	V Keyway Height	W Keyway Width	X Bolt Circle
25	2.502/2.500 (63.55/63.50)	2.601/2.591 (66.06/65.81)	.1905/.1855 (4.84/4.79)	3.00 (76.20)
55	3.002/3.000 (76.25/76.20)	3.099/3.089 (78.71/78.46)	.1905/.1885 (4.84/4.79)	3.50 (88.90)
115	4.002/4.000 (101.65/101.60)	4.127/4.117 (104.83/104.57)	.378/.376 (9.60/9.55)	4.50 (114.30)

Bore Size and Keyways

Size	Unit Bore		Key
ATC-25	.5025	12.76	1/8 Sq.
	.5005	12.71	
	.6275	15.94	3/16 Sq.
	.6255	15.89	
ATC-25	.7525	19.11	3/16 Sq.
ATC-55	.7505	19.06	
ATC-25	.8775	22.29	3/16 Sq.
ATC-55	.8755	22.24	
ATC-55	1.0025	25.46	1/4 Sq.
	1.0005	25.41	
ATC-55	1.1275	28.64	1/4 Sq.
ATC-115	1.1255	28.59	
ATC-115	1.2525	31.81	1/4 Sq.
	1.2505	31.76	
	1.3775	34.99	5/16 Sq.
	1.3755	34.94	
ATC-115	1.5025	38.16	3/8 Sq.
	1.5005	38.11	

Parts List

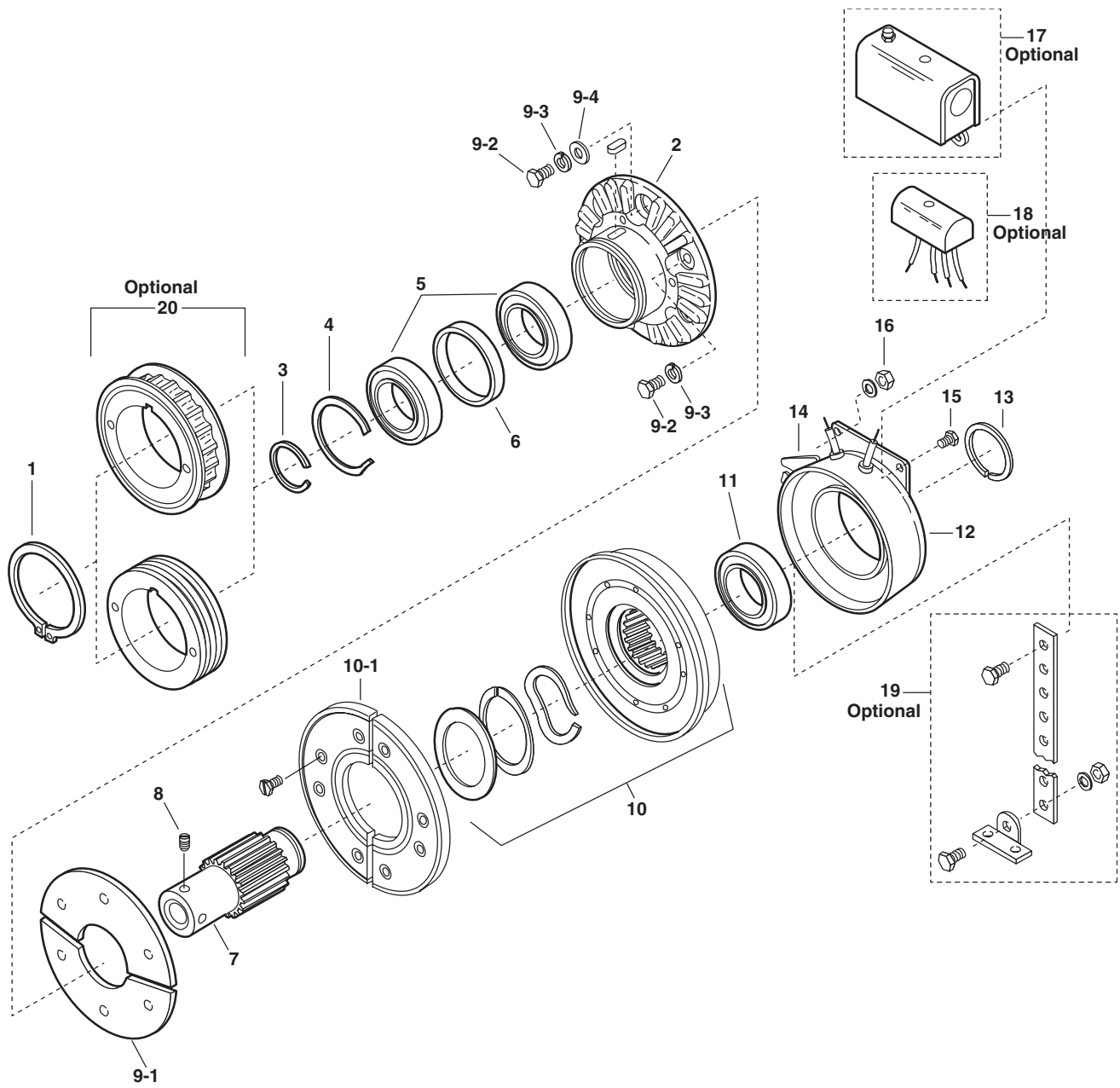

Component Parts

Item	Description	ATC-25		ATC-55		ATC-115	
		Part No.	Qty.	Part No.	Qty.	Part No.	Qty.
1	Retaining Ring	748-0734	1	748-0725	1	748-0738	1
2	Armature Hub	540-0907	1	540-0852	1	540-0863	1
3	Retaining Ring	748-0732	1	748-0726	1	748-0737	1
4	Retaining Ring	748-0731	1	748-0728	1	748-0736	1
5	Bearing	166-0278	2	166-0277	2	166-0279	2
6	Spacer	807-0119	1	807-1061	1	807-1063	1
7	Splined Hub		1		1		1
	1/2" Bore	540-0910					
	5/8" Bore	540-0911					
	3/4" Bore	540-0912		540-1501			
	7/8" Bore	540-0913		540-1502			
	1" Bore			540-1503			
	1-1/8" Bore			540-1504		540-0857	
	1-1/4" Bore					540-0858	
	1-3/8" Bore					540-0859	
	1-1/2" Bore					540-0860	
8	Setscrew	797-1393	2	797-1386	2	797-1395	2
*9-1	Armature	110-0220	1	110-0218	1	110-0223	1
*9-2	Screw	797-1519	4	797-1462	6	797-1463	6
*9-3	Lockwasher			950-0355	6	950-0355	6
*9-4	Flatwasher			950-0023	2	950-0023	2
*10	Rotor	5161-751-001	1	5162-751-001	1	5163-751-001	1
10-1	Facing Assembly	5161-445-003	1	5162-445-003	1	5163-445-003	1
*11	Bearing	166-0283	1	166-0284	1	166-0279	1
12	Field Assembly		1		1		1
	6 volts DC	5161-451-002		5162-451-002		5163-451-002	
	90 volts DC	5161-451-003		5162-451-003		5163-451-003	
	24 volts DC	5161-451-004		5162-451-004		5163-451-004	
*13	Retainer Ring	748-0018	1	748-0727	1	748-0737	1
14	Adapter					104-0300	2
15	Screw					797-1396	4
16	Lockwasher					950-0102	4
Optional Accessory Items							
17	Conduit box	5162-101-002	1	5162-101-002	1	5162-101-002	1
18	CBC-100 Control	6003-101-001	1	6003-101-001	1	6003-101-001	1
19	Restraining Arm Assembly	5162-101-004	1	5162-101-004	1	5163-101-004	1
20	Timing Belt and V Belt Pulleys; See "Standard Sheaves and Pulleys" Chart, P-1234 page 69.						
Kit Items							
	Clutch Rebuild Kit	5161-101-011	1	5162-101-011	1	5163-101-011	1
	(includes items 9-1, 9-2, 9-3, 9-4, 10, 11, 13)						
	Note: In some versions of this product, item 10 consists of a rotor and a replaceable face.						
	Friction Face Replacement Kit	5161-101-007		5162-101-007		5163-101-007	
	For Clutches with Replaceable Friction Face Only						

Refer to Service Manual P-217-1

Warranty

Warner Electric LLC warrants that it will repair or replace (whichever it deems advisable) any product manufactured and sold by it which proves to be defective in material or workmanship within a period of one (1) year from the date of original purchase for consumer, commercial or industrial use.

This warranty extends only to the original purchaser and is not transferable or assignable without Warner Electric LLC's prior consent.

Warranty service can be obtained in the U.S.A. by returning any defective product, transportation charges prepaid, to the appropriate Warner Electric LLC factory. Additional warranty information may be obtained by writing the Customer Satisfaction Department, Warner Electric LLC, 449 Gardner Street, South Beloit, Illinois 61080, or by calling 815-389-3771.

A purchase receipt or other proof of original purchase will be required before warranty service is rendered. If found defective under the terms of this warranty, repair or replacement will be made, without charge, together with a refund for transportation costs. If found not to be defective, you will be notified and, with your consent, the item will be repaired or replaced and returned to you at your expense.

This warranty covers normal use and does not cover damage or defect which results from alteration, accident, neglect, or improper installation, operation, or maintenance.

Some states do not allow limitation on how long an implied warranty lasts, so the above limitation may not apply to you.

Warner Electric LLC's obligation under this warranty is limited to the repair or replacement of the defective product and in no event shall Warner Electric LLC be liable for consequential, indirect, or incidental damages of any kind incurred by reason of the manufacture, sale or use of any defective product. Warner Electric LLC neither assumes nor authorizes any other person to give any other warranty or to assume any other obligation or liability on its behalf.

WITH RESPECT TO CONSUMER USE OF THE PRODUCT, ANY IMPLIED WARRANTIES WHICH THE CONSUMER MAY HAVE ARE LIMITED IN DURATION TO ONE YEAR FROM THE DATE OF ORIGINAL CONSUMER PURCHASE. WITH RESPECT TO COMMERCIAL AND INDUSTRIAL USES OF THE PRODUCT, THE FOREGOING WARRANTY IS IN LIEU OF AND EXCLUDES ALL OTHER WARRANTIES, WHETHER EXPRESSED OR IMPLIED BY OPERATION OF LAW OR OTHERWISE, INCLUDING, BUT NOT LIMITED TO, ANY IMPLIED WARRANTIES OF MERCHANTABILITY OR FITNESS.

Some states do not allow the exclusion or limitation of incidental or consequential damages, so the above limitation or exclusion may not apply to you. This warranty gives you specific legal rights and you may also have other rights which vary from state to state.

Changes in Dimensions and Specifications

All dimensions and specifications shown in Warner Electric catalogs are subject to change without notice. Weights do not include weight of boxing for shipment. Certified prints will be furnished without charge on request to Warner Electric.



Warner Electric LLC
449 Gardner Street • South Beloit, IL 61080
815-389-3771 • Fax: 815-389-2582
www.warnerelectric.com